

INTERSCHOLASTIC SAILING ASSOCIATION
GREAT OAKS INVITATIONAL REGATTA
NOVEMBER 11 – 12, 2006

SOUTHERN YACHT CLUB
NEW ORLEANS, LA

Sailing Instructions

1. RULES

- 1.1 This regatta will be governed by the 2005-2008 Racing Rules of Sailing (RRS), the Prescriptions of the U. S. Sailing Association, the 2005-2008 Procedural Rules of the Interscholastic Sailing Association (ISSA), the Notice of Race and by these Sailing Instructions. In the event of a conflict between the Sailing Instructions and any Rule, the Sailing Instructions shall prevail.

2. ENTRIES

- 2.1 All entries must be a current member in good standing of ISSA.

3. NOTICE TO COMPETITORS

- 3.1 Notices by the Race Committee may be oral or in writing and may be given at any time during the regatta. Written notices will be posted on the official bulletin board which will be located in the Southern Yacht Club (SYC) lobby.

4. CHANGES TO THE SAILING INSTRUCTIONS

- 4.1 Any changes in the Sailing Instructions will be posted on the official bulletin board. At the sole discretion of the Race Committee, oral instructions may be given on the water.

5. SIGNALS MADE ASHORE

- 5.1 Signals made ashore will be displayed from the flagpole immediately to the East of the SYC clubhouse.
- 5.2 Code flag "AP" means that "races not started are postponed – do not leave the harbor area". The time of the next Warning Signal will be posted on the official bulletin board prior to lowering "AP". This alters race signal "AP".

6. BOATS/EQUIPMENT/SUBSTITUTIONS

- 6.1 Club 420's, without trapeze or spinnaker gear, will be provided for all competitors by SYC, Tulane University, the University of New Orleans, the GYA and many SEISA teams.
- 6.2 ISSA Procedural Rules regarding equipment shall apply.
- 6.3 The penalty for infringement of ISSA Procedural Rule 4 will be disqualification from all races sailed in contravention of these instructions.
- 6.4 Competitors shall report any damage to boats and equipment or loss of equipment, however slight, to the Race Committee immediately upon completion of the race in which it occurs. The penalty for infringement of this instruction, unless the jury is satisfied that the competitor made a determined effort to comply, may be disqualification of the crew from the race or series.

7. SCHEDULE OF RACES

7.1 Saturday, November 11, 2006

0830 – Rigging of Boats

0900 – Skippers Meeting at SYC

1030 – First Warning Signal. Racing will continue throughout the day.
Lunch on the water.

7.2 Sunday, November 12, 2006

0830 – Rigging of Boats

0900 – Skippers Meeting at SYC

1030 – First Warning Signal. Racing will continue throughout the day.
Lunch on the water.

1600 -- No race will be started after this time.

8. FORMAT OF REGATTA

8.1 Boats will be divided into two fleets for the each day of racing.

8.2 Boats will be assigned randomly during registration. Green fleet will be composed of boats with odd numbered bow numbers and red fleet will be composed of boats with even bow numbers. The green fleet and the red fleet will be started separately on the first day of sailing. Class flag will be red for the red fleet and green for the green fleet.

8.3 At the end of the first day of racing the boats will again be divided into two fleets and assigned randomly. Boats finishing in the top half of the green and red fleets will form a new gold fleet for the second day of racing. The boats finishing in the bottom half of both fleets will form the silver fleet for the second day of racing. The gold and silver fleets will be started separately on the second day of racing. Class flag will be yellow for the gold fleet and white for the silver fleet.

8.4 Fleet assignments and boat rotation details will be distributed at the Skippers Meeting each morning for that day's races.

9. RACING AREA

9.1 The racing area will be northeast of SYC on the waters of Lake Pontchartrain.

10. MARKS

10.1 Marks will be orange spheres.

11. THE COURSES

11.1 All courses will be in accordance with ISSA Procedural Rule 7.7.

11.2 Course diagrams with identifying names and numbers in 11.5 below show the courses, and the order and the side on which each mark is passed.

11.3 The identifying number of the course will be given orally or displayed by the race committee boat before the Warning Signal.

- 11.4 The starting and finishing marks are not marks of the course except when starting or finishing. The gate formed by the start/finish mark and the race committee boat is open to all boats not starting or finishing.

- | | | | |
|------|----------------------------|--------------------------------------|---------------------------|
| 11.5 | <u>Course "1"</u> | <u>Course "2"</u> | <u>Course "3"</u> |
| | Triangle | Triangle/ Windward/ Leeward/Windward | Windward/Leeward/Windward |
| | Start - 1 - 2 - 3 - Finish | Start -1-2-3-1-3- Finish | Start – 1 – 2 – Finish |

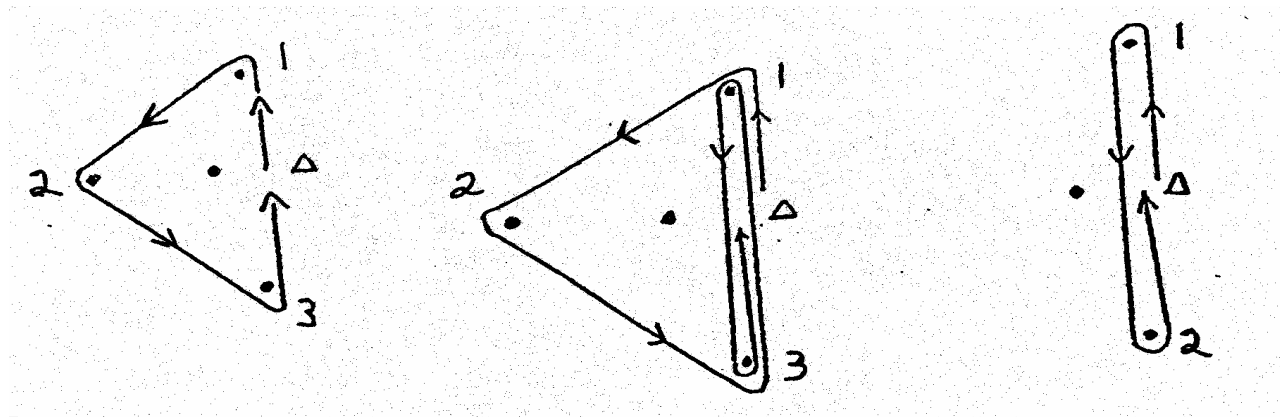

12. **THE START**

- 12.1 Races will be started in accordance with ISSA Procedural Rule 7.8 and RRS U S Sailing Prescription Appendix Q – Sound Signal Starting System.
- 12.2 The starting line will be between a staff displaying an orange flag on a race committee boat and the adjacent mark, or as described at the skipper's meeting.
- 12.3 The Fleet whose warning signal has not been made shall avoid the starting area.
- 12.4 A boat starting later than five (5) minutes after her starting signal will be scored DNS without a hearing. This changes Rule A 4.1.

13. **RECALLS**

- 13.1 Individual Recalls will be signaled by an attempted verbal hail of the bow or sail number and the display of the flag "X" by the race committee boat.
- 13.2 A General Recall will be signaled by the verbal hail and/or multiple sound signals and the display of "First Substitute" on the race committee boat. The three minute starting sequence (Warning) will begin soon after the lowering of "First Substitute".
- 13.3 After a General Recall, the "Round-an-End" penalty [RRS 30.1] applies for subsequent start(s) of that race. Code Flag "I" need not be displayed.

14. **ABANDONMENT**

- 14.1 The Race Committee may abandon any race in progress when a change in weather conditions has, in its judgment, made the race an unsatisfactory test of skill.

15. THE FINISH

- 15.1 The finish line will be between a staff displaying an orange flag on a race committee boat and the adjacent mark, or as described at the skipper's meeting.
- 15.2 If a boat is unreasonably delaying completion of a race, the Race Committee may, at its sole discretion, give the boat a finish and score her points equal to the last place.

16. SAFETY

- 16.1 A boat that retires from a race is required to notify the Race Committee either before leaving the course area or, if that is impossible, the SYC office and/or the Race Committee immediately after arriving ashore. Failure to report may subject the skipper of the violating boat to disqualification.
- 16.2 Competitors shall provide and wear USCG approved personal flotation devices at all times while on the water, in accordance with ISSA Procedural Rule 2.2. Competitors may not protest one another over compliance with this instruction.

17. SCORING

- 17.1 Scoring will be in accordance with ISSA Procedural Rule 11. Each Team must complete, sign, and submit a Record of Participation Form before the expiration of Protest Time at the end of the regatta. Failure to do so will result in a 20 point penalty added to the total team score.
- 17.2 Scores from Saturday's races will be used to determine the composition of the gold and silver fleets for Sunday's races.
- 17.3 Scores from Sunday's races only will be used to determine finish positions in the gold and silver fleets.

18. PROTESTS

- 18.1 Protests shall be written on forms available in the lobby or office of SYC and delivered to the office no later than one hour from the official docking time of the Race Committee boat. The official docking time will be posted on the official bulletin board.
- 18.2 Protests will be heard in approximately the order of receipt as soon as possible.

19. BREAKDOWNS

- 19.1 Breakdown points will be awarded using the principles outlined in RRS D5.

20. COACHING

- 20.1 Coaching will be governed by ISSA Procedural Rule 8. The float is an extension of the land and sailors and coaches are allowed on the float.

21. AWARDS

- 21.1 Trophies will be awarded to the top three finishers in the gold fleet and to the top two finishers in the silver fleet.